

GCS7L0C45

BIDI SFP+,10 Gb/s, 1490nm,SMF, 80KM ,DDM,LC connector, 0 °C ~ +70°C

Features

- Up to 10.7Gbps Data Links
- Single Mode LC Receptacle Bi-directional Transceiver
- Up to 80km transmission on SMF
- Power dissipation<1.5W
- 1490nm EML laser and 1550nm APD receiver
- 2-wire interface with integrated Digital Diagnostic monitoring
- EEPROM with Serial ID Functionality
- Compliant with FC_PI_4 REV 7.0
- Compliant with SFP+ MSA with duplex LC connector
- Single + 3.3V Power Supply and LVTTL Logic
- Operating case temperature: 0~+70° C

Applications

- 10GBASE-BX at 10.3125 Gb/s
- 10GBASE-BX at 9.953 Gb/s
- 1000 Base-LX Ethernet
- 8XFC at 8.5Gbps
- 4XFC at 4.25Gpbs
- 2XFC at 2.125Gpbs
- 1xFC at 1.0625Gbps

BIDI-SFP+-ZR-49 is hot pluggable 3.3V Small-Form-Factor transceiver module. It designed expressly for highspeed communication applications that require rates up to 10.7 Gb/s, it designed to be compliant with SFF-8472 SFP+ MSA. The module data link up to 80km in 9/125um single mode fiber.

The optical output can be disabled by a LVTTL logic high-level input of Tx Disable. Tx Fault is provided to indicate that degradation of the laser. Loss of signal (LOS) output is provided to indicate the loss of an input optical signal of receiver or the link status with partner.

Absolute Maximum Ratings

Parameter	Symbol	Min.	Typ.	Max.	Unit	Note
Storage Temperature	Ts	-40	-	85	°C	
Storage Ambient Humidity	HA	5	-	95	%	
Operating Relative Humidity	RH	-	-	85	%	
Power Supply Voltage	VCC	-0.3	-	4	V	
Signal Input Voltage		Vcc-0.3	-	Vcc+0.3	V	

Recommended Operating Conditions

Parameter	Symbol	Min.	Typ.	Max.	Unit	Note
Ambient Operating	TA	0	-	70	°C	Without air flow
TemperaturePower Supply Voltage	VCC	3.14	3.3	3.47	V	
Power Supply Current	ICC	-	300	450	mA	
Data Rate	BR		10.3125		Gbps	
Transmission Distance	TD		-	80	km	Note (1)
Coupled fiber	Single mode fiber					ITU-T G.652

Note:

1. Measured with SMF

Specification of Transmitter

Parameter	Symbol	Min.	Typ.	Max.	Unit	Note
Average Launched Power	PO	0	-	5	dBm	
Average Launched Power(Laser Off)	POUTOFF	-	-	-30	dBm	Note (1)
Optical Modulation Amplitude	OMA	-3	-	-	dBm	Note (1)
Center Wavelength Range	λ_C	1470	1490	1510	nm	
Side mode suppression ratio	SMSR	30	-	-	dB	
Spectrum Bandwidth(-20dB)	σ	-	-	1	nm	
Extinction Ratio	80KM	7.5		-	dB	Note (2)
Output Eye Mask	Compliant with FC_PI_4 REV 7.0					Note (2)

Note:

1.The optical power is launched into SMF

2. Measured with RPBS 2^31-1 test pattern @10.3125Gbs

Specification of Receiver

Parameter	Symbol	Min.	Typ.	Max.	Unit	Note
Input Optical Wavelength	λ_{IN}	1530	1550	1570	nm	
Receiver Sensitivity in average	PIN	-	-	-24	dBm	Note (1)
Input Saturation Power (Overload)	PSAT	0.5	-	-	dBm	Note (1)
LOS -Assert Power	PA	-38	-	-	dBm	
LOS -Deassert Power	PD	-	-	-26	dBm	
LOS -Hysteresis	PHys	0.5	-	8	dB	

Note:

1. Measured with RPBS 2^31-1 test pattern @10.3125Gbs BER= $\leq 10^{-2}$

Optical and Electrical Characteristics

Parameter	Symbol	Min.	Typ.	Max.	Unit	Note
Total power supply current	Icc	-	300-	450	mA	
Transmitter						
Differential Data Input Voltage	VDT	180	-	700	mVp-p	
Differential line input Impedance	RIN	85	100	115	Ohm	
Transmitter Fault Output-High	VFaultH	2.4	-	Vcc	V	
Transmitter Fault Output-Low	VFaultL	-0.3	-	0.8	V	
Transmitter Disable Voltage- High	VDisH	2	-	Vcc+0.3	V	
Transmitter Disable Voltage- low	VDisL	-0.3	-	0.8	V	
Receiver						
Differential Data Output Voltage	VDR	300	-	850	mVp-p	
Differential line Output Impedance	ROUT	80	100	120	Ohm	
Receiver LOS Pull up Resistor	RLOS	4.7	-	10	KOhm	
Data Output Rise/Fall time	tr/tf	20	-	-	ps	
LOS Output Voltage-High	VLOSH	2	-	Vcc	V	
LOS Output Voltage-Low	VLOSL	-0.3	-	0.4	V	

Pin Descriptions

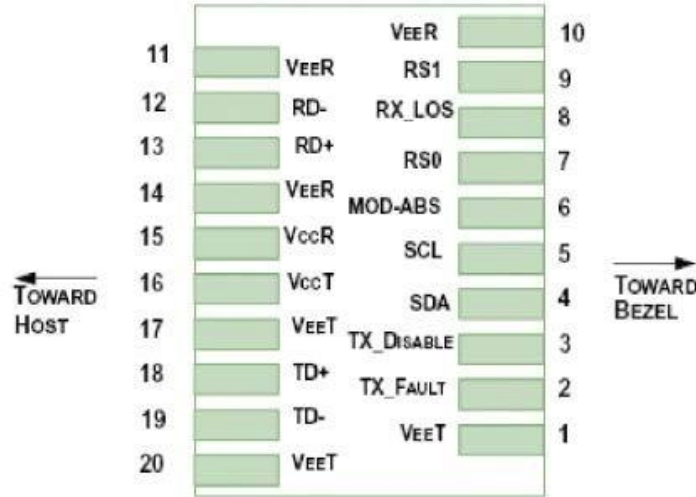

Pin Num.	Name	Function	Notes
1	VeeT	Transmitter Ground	
2	TX Fault	Module Transmitter Fault	Note 1
3	TX Disable	Transmitter Disable; Turns off transmitter laser output	Note 2 Module disables on high or open
4	SDA	2-wire Serial Interface Data Line (Same as MOD-DEF2 as defined in the INF-8074i)	Note 3, 2 wire serial ID interface
5	SCL	2-wire Serial Interface Clock (Same as MOD-DEF1 as defined in the INF-8074i)	Note 3, 2 wire serial ID interface
6	MOD-ABS	Module Absent, connected to VeeT or VeeR in the module	Note 3, Grounded in Module
7	RS0	Not used	Function not available
8	RX_LOS	Receiver Loss of Signal Indication (In FC designated as RX_LOS, in SONET designated as LOS, and in Ethernet designated as Signal Detect)	Note 4
9	RS1	Not used	Function not available
10	VeeR	Module Receiver Ground	Note 5
11	VeeR	Module Receiver Ground	Note 5
12	RD-	Receiver Inverted Data Output	Note 6
13	RD+	Receiver Non-Inverted Data Output	Note 7
14	VeeR	Module Receiver Ground	Note 5
15	VccR	Module Receiver 3.3 V Supply	3.3 ± 5%, Note 7
16	VccT	Module Transmitter 3.3 V Supply	3.3 ± 5%, Note 7
17	VeeT	Module Transmitter Ground	Note 5
18	TD+	Transmitter Non-Inverted Data Input	Note 8
19	TD-	Transmitter Inverted Data Input	Note 8
20	VeeT	Module Transmitter Ground	Note 5

NOTE:

1. TX Fault is an open collector/drain output, which should be pulled up with a 4.7K – 10KΩ resistor on the host board. Pull up voltage between 2.0V and VccT, R+0.3V. When high, output indicates a laser fault of some kind. Low indicates normal operation. In the low state, the output will be pulled to < 0.8V.
2. TX disable is an input that is used to shut down the transmitter optical output. It is pulled up within the module with a 4.7 – 10 K Ω resistor. Its states are: Low (0 – 0.8V): Transmitter on (>0.8, < 2.0V): Undefined High (2.0 – 3.465V): Transmitter Disabled Open: Transmitter Disabled.
3. Mod-Def 0,1,2. These are the module definition pins. They should be pulled up with a 4.7K – 10KΩ resistor on the host board. The pull-up voltage shall be VccT or VccR (see Section IV for further details). ModDef 0 is grounded by the module to indicate that the module is present Mod-Def 1 is the clock line of two wire serial interface for serial ID Mod-Def 2 is the data line of two wire serial interface for serial ID.
4. LOS (Loss of Signal) is an open collector/drain output, which should be pulled up with a 4.7K – 10KΩ resistor. Pull up voltage between 2.0V and VccT, R+0.3V. When high, this output indicates the received optical power is below the worst-case receiver sensitivity (as defined by the standard in use). Low indicates normal operation. In the low state, the output will be pulled to < 0.8V.
5. VeeR and VeeT may be internally connected within the SFP module.
6. RD-/+ : These are the differential receiver outputs. They are AC coupled 100Ω differential lines which should be terminated with 100Ω (differential) at the user SERDES. The AC coupling is done inside the module and is thus not required on the host board. The voltage swing on these lines will be between 370 and 2000 mV differential (185 – 1000 mV single ended) when properly terminated.
7. VccR and VccT are the receiver and transmitter power supplies. They are defined as 3.3V ±5% at the SFP connector pin. Maximum supply current is 300mA. Recommended host board power supply filtering is shown below. Inductors with DC resistance of less than 1 ohm should be used in order to maintain the required voltage at the SFP input pin with 3.3V supply voltage. When the recommended supply-filtering network is used, hot plugging of the SFP transceiver module will result in an inrush current of no more than 30mA greater than the steady state value. VccR and VccT may be internally connected within the SFP transceiver module.
8. TD-/+ : These are the differential transmitter inputs. They are AC-coupled, differential lines with 100Ω differential termination inside the module. The AC coupling is done inside the module and is thus not required on the host board. The inputs will accept differential swings of 500 – 2400 mV (250 – 1200 mV single-ended), though it is recommended that values between 500 and 1200 mV differential (250 – 600 mV single-ended) be used for best EMI performance.

Recommended Interface Circuit

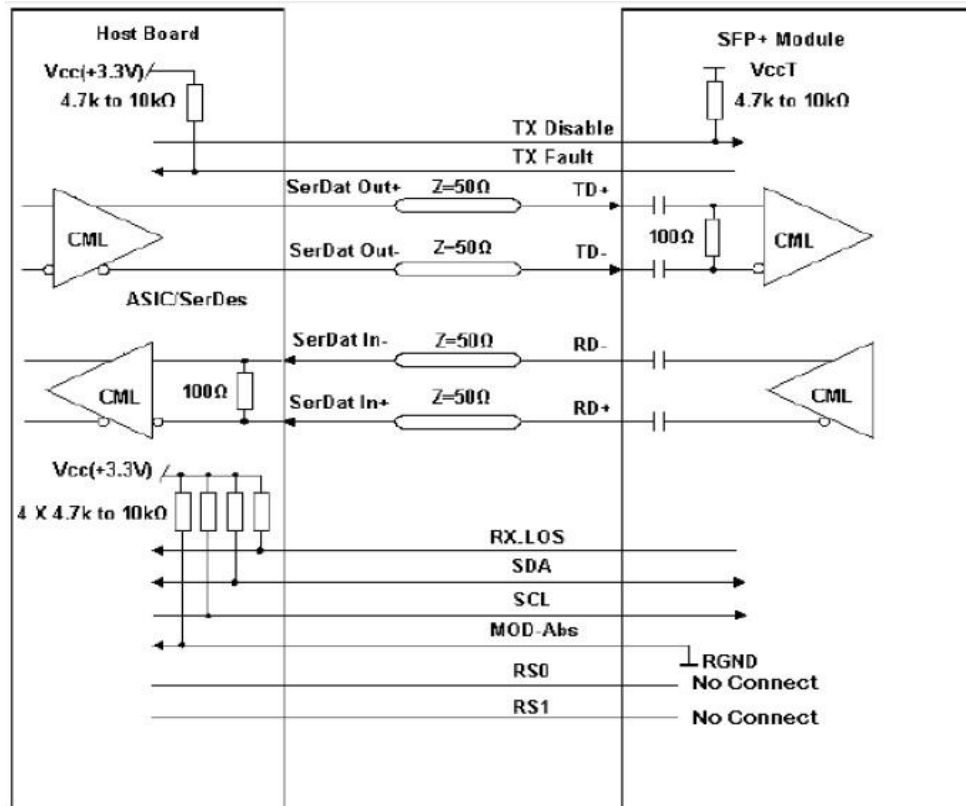

Outline Dimensions

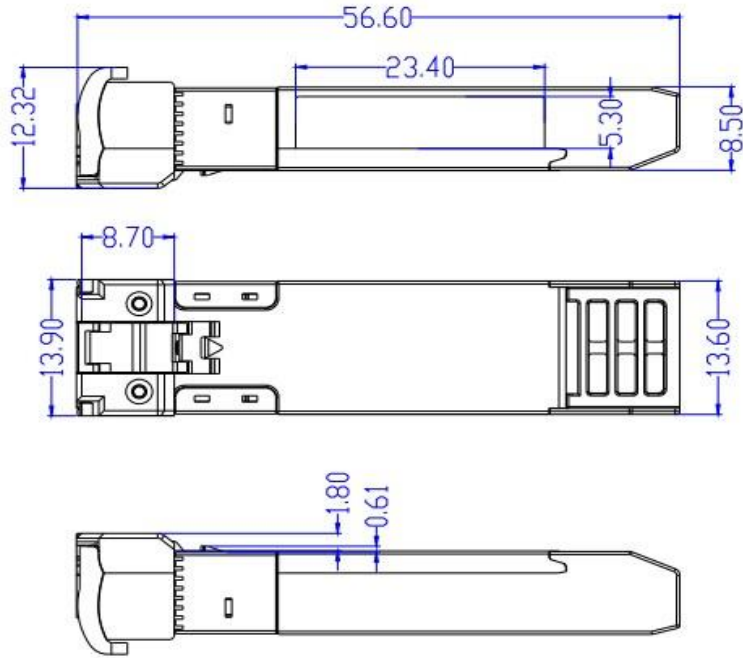

Ordering information

Part Number	Product Description
GHS7L0C45	BIDI SFP+,10 Gb/s, 1490nm,SMF, 80KM ,DDM,LC connector, 0°C ~ +70°C