

GJSX0ACXX

25Gb/s SFP28 Active Optical Cable

Features:

- Electrical interface compliant to SFF-8431
- 850nm VCSEL laser and PIN photo-detector
- Maximum link length of 70m on OM3 MMF and 100m on OM4 MMF
- Digital diagnostics functions are available via the I2C interface
- Operating case temperature Commercial: 0°C to +70 °C
- +3.3V single power supply
- Power consumption less than 1W
- RoHS compliant



Applications

- 25GBASE-SR Ethernet
- Servers, switches, storage and host card adapters

General Description

The GearLink’s SFP28 Active Optical Cables are direct-attach fiber assemblies with SFP28 connectors. They have very good power consumption performance. They are suitable for very short distances and offer a cost-effective way to connect within racks and across adjacent racks. The length of GearLink’s SFP28 Active Optical Cables is up to 70 meters on OM3 MMF.

Absolute Maximum Ratings

Parameter	Symbol	Min.	Typical	Max.	Unit	Notes
Supply Voltage	Vcc3	-0.5	-	+3.6	V	
Storage Temperature	Ts	-40	-	+85	°C	
Operating Humidity	RH	5	-	85	%	1

Note:
1 No condensation

Recommended Operating Conditions

Parameter	Symbol	Min.	Typical	Max.	Unit	Notes
Operating Case Temperature	T _c	0	-	+70	°C	
Power Supply Voltage	V _{cc}	3.14	3.3	3.47	V	
Power Supply Current	I _{cc}	-	-	300	mA	
Power Dissipation	P _d	-	-	1.0	W	
Bit Rate	BR	8.5	25.78125	-	Gbps	

Electrical Characteristics

Parameter	Symbol	Min.	Typ.	Max.	Units	Notes
Transmitter						
Differential Data Input Swing	V _{in,P-P}	200	-	1600	mV _{PP}	
Input Differential Impedance	Z _{IN}	90	100	110	Ω	
Tx_Fault	Normal Operation	V _{OL}	0	-	0.8	V
	Transmitter Fault	V _{OH}	2.0	-	V _{CC}	V
Tx_Disable	Normal Operation	V _{IL}	0	-	0.8	V
	Laser Disable	V _{IH}	2.0	-	V _{CC} +0.3	V
Receiver						
Differential Data Output	V _{out}	400	-	800	mV	
Output Differential Impedance	Z _D	90	100	110	Ω	
Rx_LOS	Normal Operation	V _{OL}	0	-	0.8	V
	Lose Signal	V _{oH}	2.0	-	V _{CC}	V

Optical Characteristics

Parameter	Symbol	Unit	Min	Typ	Max	Notes
Optical transmitter Characteristics						
Bit Rate	BR	Gbps	8.5	25.78125	-	
Center Wavelength Range	λ _c	nm	820	850	880	
Average Launch power Tx_off	P _{off}	dBm	-	-	-45	
Launch Optical Power	P ₀	dBm	-6.0		2.4	1
Extinction Ratio	ER	dB	2	-	-	
Optical Receiver Characteristics						
Bit Rate	BR	Gbps	8.5	25.78125		
Bit Error Rate	BER		-	-	E-12	
Overload Input Optical Power	P _{IN}	dBm	2.4	-	-	2
Center Wavelength Range	λ _c	nm	820	-	880	

Note:

1. Coupled into 50/125 MMF.
2. Measured with PRBS²³¹-1 test pattern @25.78125Gbps. BER=E-12

Recommended Host Board Power Supply Circuit

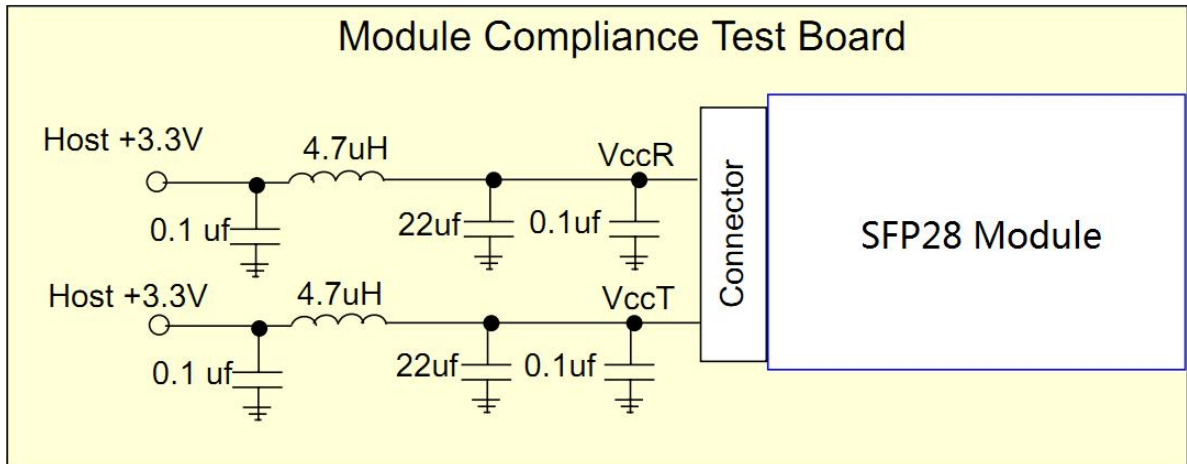

Recommended Interface Circuit

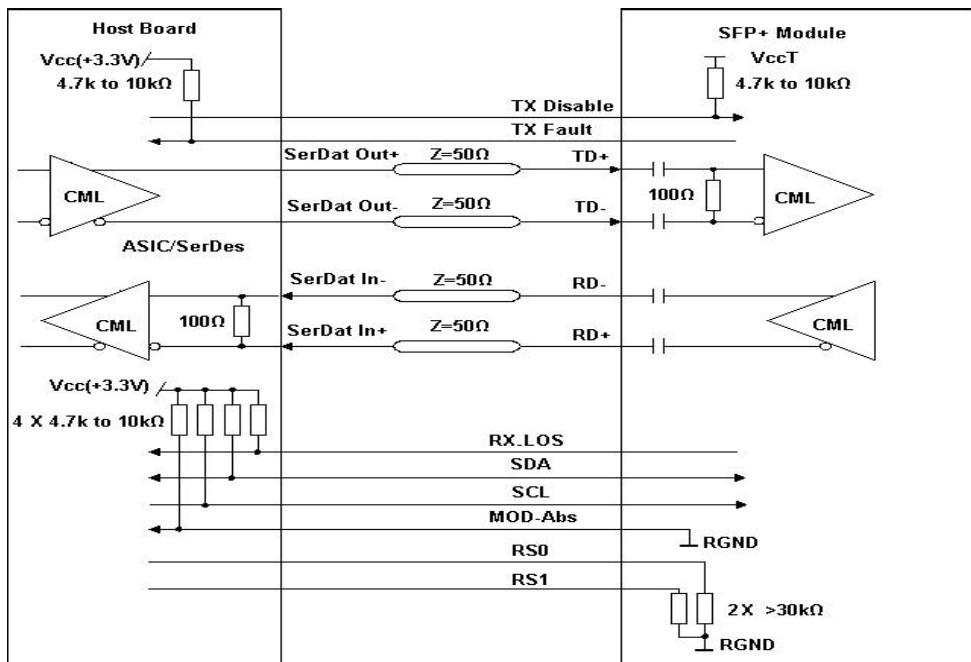

Pin Assignment

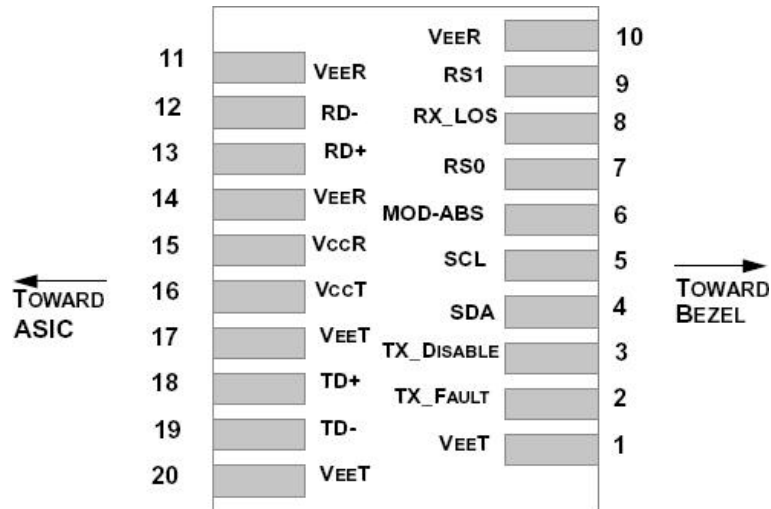

Pin Description

Pin	Symbol	Name/Description	Notes
1	VEET	Module Transmitter Ground	1
2	TX_FAULT	Module Transmitter Fault	2
3	TX_DISABLE	Transmitter Disable; Turns off transmitter laser output	3
4	SDA	2-Wire Serial Interface Data Line (MOD-DEF2)	
5	SCL	2-Wire Serial Interface Clock (MOD-DEF1)	
6	MOD_ABS	Module Absent, connected to V _{EE} T or V _{EE} R in the module	2
7	RS0	Rate Select 0, optionally controls SFP+ module receiver	4
8	RX_LOS	Receiver Loss of Signal Indication (In FC designated as Rx_LOS and in Ethernet designated as NOT Signal Detect)	2
9	RS1	Rate Select 1, optionally controls SFP+ module transmitter	4
10	V _{EE} R	Module Receiver Ground	1
11	V _{EE} R	Module Receiver Ground	1
12	RD-	Receiver Inverted Data Output	
13	RD+	Receiver Non-Inverted Data Output	
14	V _{EE} R	Module Receiver Ground	1
15	V _{CC} R	Module Receiver 3.3 V Supply	
16	V _{CC} T	Module Transmitter 3.3 V Supply	
17	V _{EE} T	Module Transmitter Ground	1
18	TD+	Transmitter Non-Inverted Data Input	
19	TD-	Transmitter Inverted Data Input	
20	V _{EE} T	Module Transmitter Ground	1

Note:

1. The module ground pins are isolated from the module case.
2. The pins shall be pulled up with 4.7K-10Kohm to a voltage between 3.14V and 3.46V on host board.
3. The pin is pulled up to VCCT with a 4.7K-10KΩ resistor in the module.
4. See SFF-8472 Rev12.2 Table 10-2.

Monitoring Specification

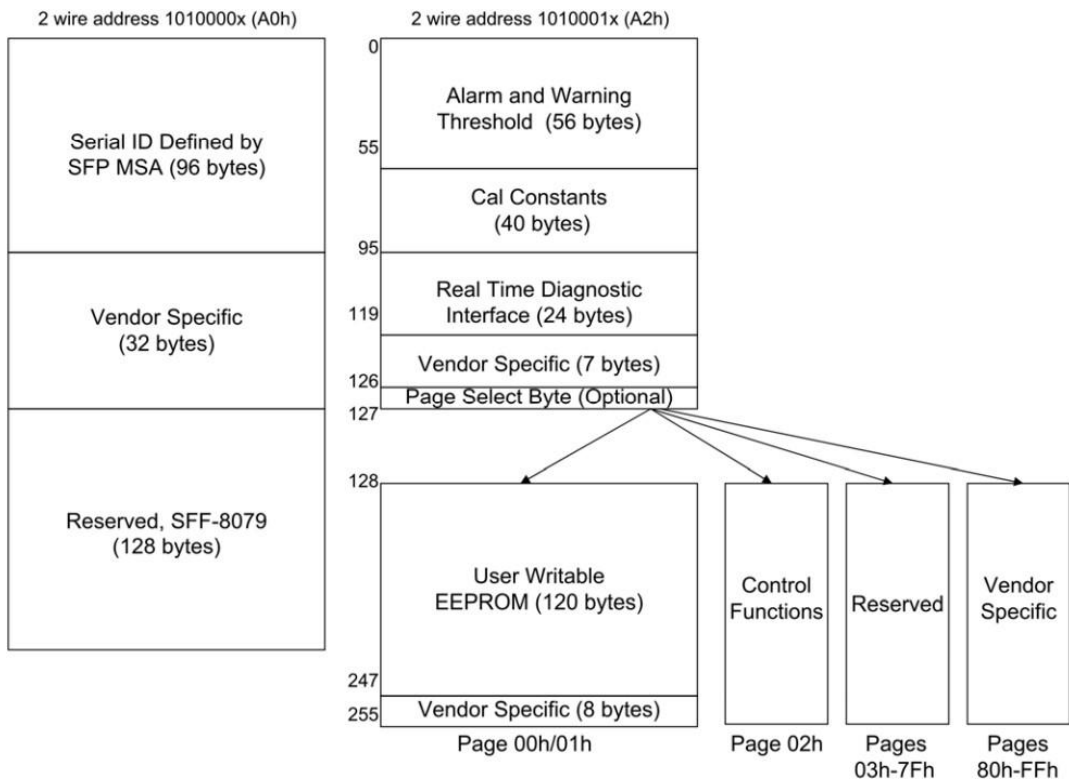

Mechanical Dimensions

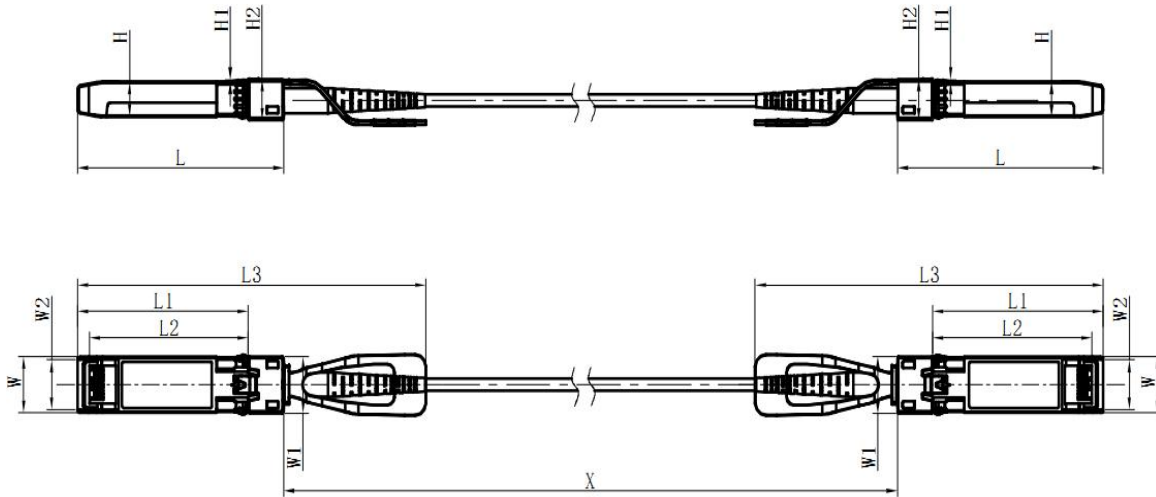

Unit: mm

	L	L1	L2	L3	W	W1	W2	H	H1	H2
MAX	57.75	48.0	44.65	102.5	13.75	14.0	12.25	8.65	0.55	10.4
Typical	57.55	47.8	44.45	101.5	13.65	13.9	12.15	8.55	0.5	10.2
MIN	57.35	47.6	44.25	100.5	13.55	13.8	12.05	8.45	0.45	10.0

Handling Precautions: This device is susceptible to damage as a result of electrostatic discharge (ESD).
 A static free environment is highly recommended. Follow guidelines according to proper ESD procedures.
Laser Safety: Radiation emitted by laser devices can be dangerous to human eyes. Avoid eye exposure to direct or indirect radiation.

Ordering Information

GJSX0ACXX	25G SFP28 Active Optical Cable with operate temperature 0°C~70°C
-----------	--